

CASE STUDY

Bartels  mikrotechnik

with passion for microfluidics

Droplet generation
with the mp6
micropump and
microfluidic chips

August 2021

Author:
Anja Blase

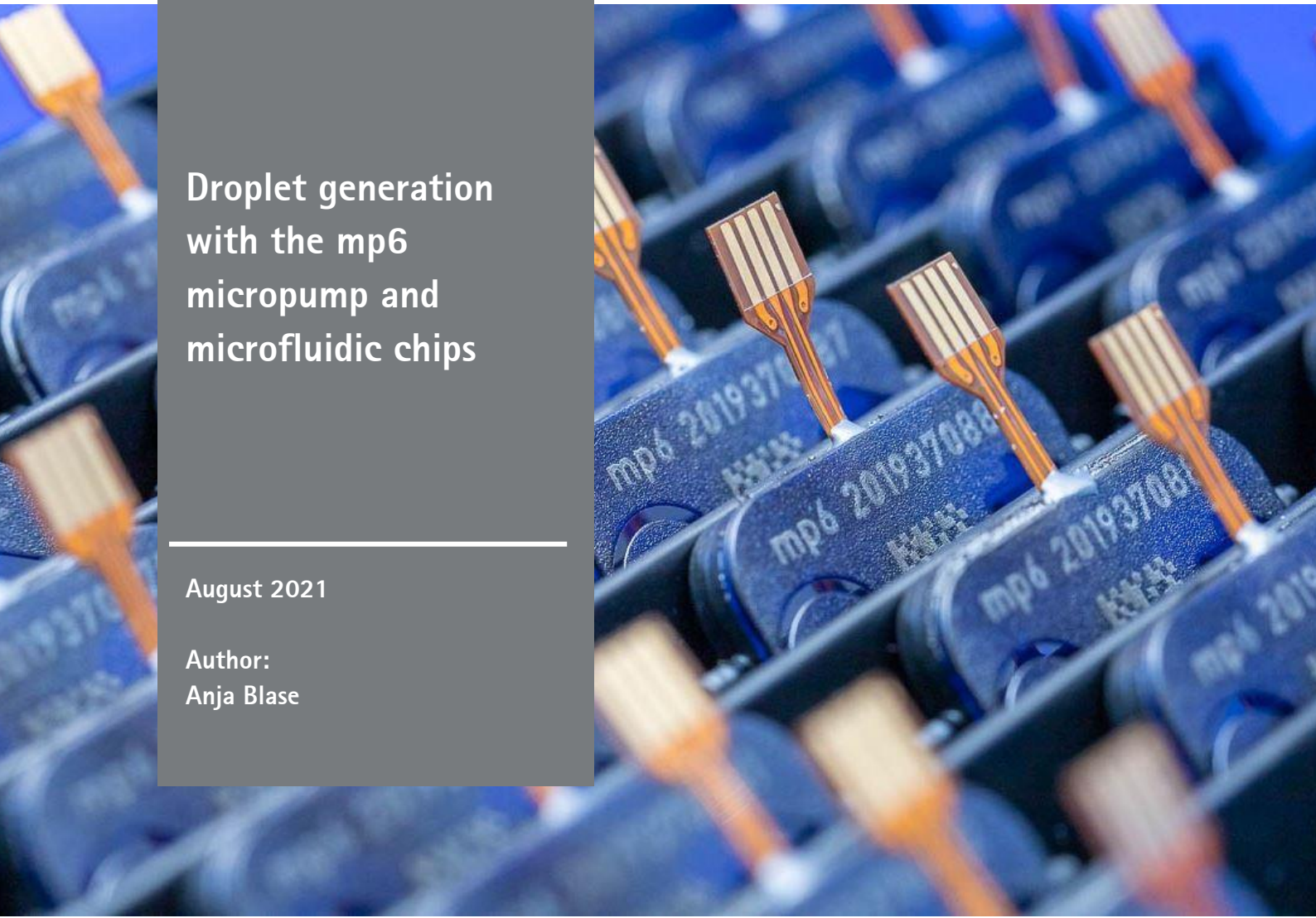



Single cell
analysis & sorting

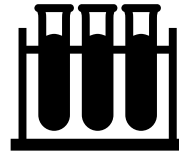

Ultra small reaction volume

Droplet-based microfluidic systems have found their way into laboratories as it is possible to generate (monodisperse) droplets in the femto- to nanoliter scale. So, they opened up unlimited experimental possibilities like digital PCR and single cell experiments where the compartmentalization and surface-to-volume ratio are important.

Droplet generation in microfluidics is based on the use of two immiscible phases that are referred to as the continuous phase (oil, medium in which droplets flow) and dispersed phase (water, the droplet). For generating droplets, microfluidic systems generally include a microfluidic chip, a fluid handling system and tubing. This system is usually connected to a computer and a microscope to visualize droplet formation.

The objective of this case study is to demonstrate droplet generation using the mp6 micropump with a pressure sensor, reagents, fluidic accessories and a Droplet Generator Chip obtained from our partner *microfluidic ChipShop*.

What is microfluidics?

Microfluidics is the fine art of creation and manipulation of small portions of fluids, often realized by flow within small, sub-millimeter-scale channels. These small dimensions allow the fluid flow to be controlled with exquisite precision (Seifert, Thiele; 2020).

About the mp6 micropump

The available, industrialized and commercialized example is the mp6 micropump by Bartels Mikrotechnik GmbH. This micro pump is a positive displacement membrane pump utilizing piezo buzzers. The alternating displacement of the piezo acutators lead to the following typical fluidic values of the pump:

- Liquids ($\eta = 1 \text{ mPas}$): $q = 5 - 8000 \mu\text{l}/\text{min}$ in free flow and $p > 600 \text{ mbar}$
- Gas: $q > 25 \text{ ml}/\text{min}$ in free flow and $p > 150 \text{ mbar}$

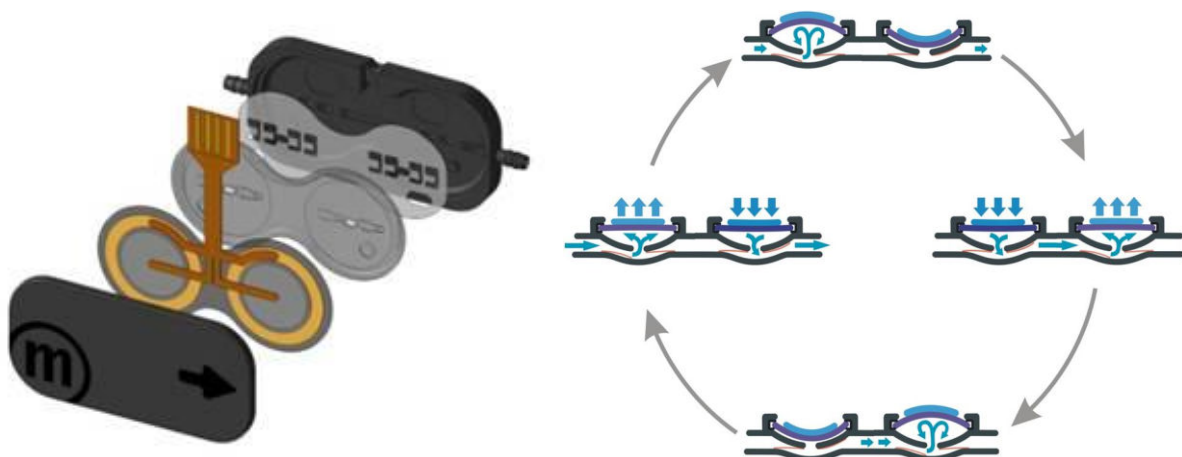

All values are approximate and no guarantee of specific technical properties.
Changes in the course of technical progress are possible without notice.

Droplet Generator Chips

To generate droplets many different chips can be used, each with its advantages. For this case study two chips are selected to show droplet generation in an easy way.

Fluidic 912 – Single Cross Geometry

The droplet generator chip Fluidic 912 provides eight identical droplet generator units with a nozzle size of $80\ \mu\text{m}$ on the chip (see Figure 1). The continuous phase is introduced through one Mini Luer inlet, which separates into two channels. Operation of one unit of Fluidic 912 therefore requires a control unit with the ability to control two individual flows, one for the continuous and one for the disperse phase. This can be realized with the mp-Multiboard as explained in the experimental setup.

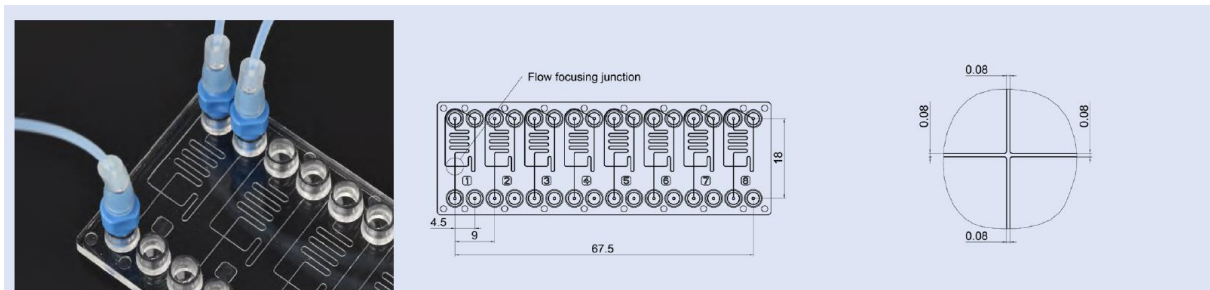

Figure 1: Microfluidic chip 912 – single cross Geometry from our partner microfluidic ChipShop with Mini Luer interfaces for W/O droplet generation (Left), schematic drawing (middle) and flow focusing junction in detail (right)

Fluidic 1032 – Double Cross Geometry

This droplet generator chip with three identical droplet generation units of double cross geometry with a flow focusing nozzle size of $100\ \mu\text{m}$ was specifically developed for use in single cell sequencing experiments, where single cells and beads/lysis buffer need to be introduced into a single droplet in an oil phase. Fluidic 1032 features Mini Luer interfaces and its use requires a microfluidic pump setup with the ability to control three individual flows. It is, however, also possible to use this droplet generator to generate water in oil droplets by simply closing one inlet and supplying only two inlets with a liquid stream.

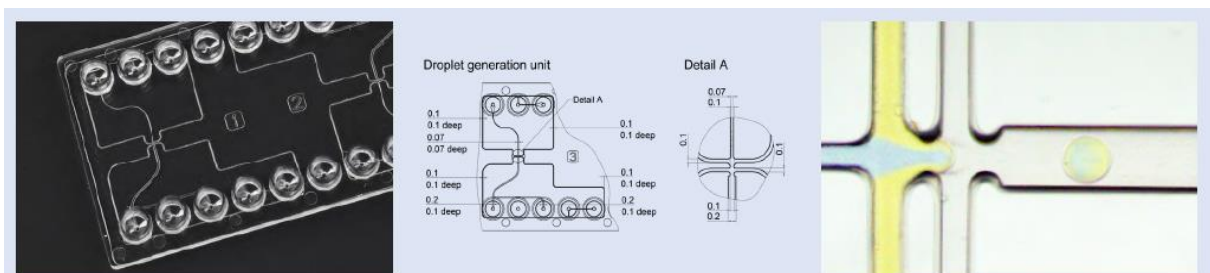

Figure 2: Microfluidic chip 1032 – double cross Geometry from our partner microfluidic ChipShop with Mini Luer interfaces for W/W/O droplet generation (Left) for W/W/O droplet generation, schematic drawing (middle) and flow focusing junction in detail (right)

Experimental Setup – Overview

For this case study, the following components are used to generate droplets:

1. **Microfluidic droplet generation chip**
2. **Fluidic accessories like**
 - a. Fluidic interfaces: e.g. Male Mini Luer Fluid Connectors – Fluidic 331
 - b. mp-t (1,3 mm) Tubing
 - c. Handling frame for convenient handling
3. **Reagents in a reservoir**
 - a. Surfactant containing droplet oil (continuous phase)
 - b. Water (dispersed phase)
4. **Pump setup including driver unit**
 - a. mp-Multiboard with mp-Highdriver4
 - b. 2-3 mp6 micropumps

As described above, two microfluidic chips are used in two applications for this case study. In general the setup is easy to adjust. You just need one more mp6 micropump for the application with chip 1032. A scheme of the microfluidic setup is presented in Figure 2 and Figure 3.

The mp6 micropumps are controlled by the mp-Highdriver4, which means that four pumps can be controlled at same time. The set frequency is the same for all pumps, but it is possible to set the voltage individually for every pump. The resulting flowrate can be set individually for water and oil pumping.

In addition, one pressure sensor can be combined to measure the pressure and to adjust the droplet size. The pressure applied ranges from 50 to 100 mbar for DI-water and 80 to 195 mbar for oil depending on the droplet size and droplet generation rate. The generated droplets are visualized with a microscope in Table 1 for microfluidic chip 912.

It can be observed that with increasing water-flow-rate, respectively water pressure, and constant oil flow rate, respectively water pressure, the droplet diameter and the generation rate increase. By decreasing the oil flow-rate, respectively oil pressure and keeping the water flowrate constant, the droplet diameter increases. All details are summarized in Figure 6.

Case study: Droplet generation with the mp6 micropump
August 2021

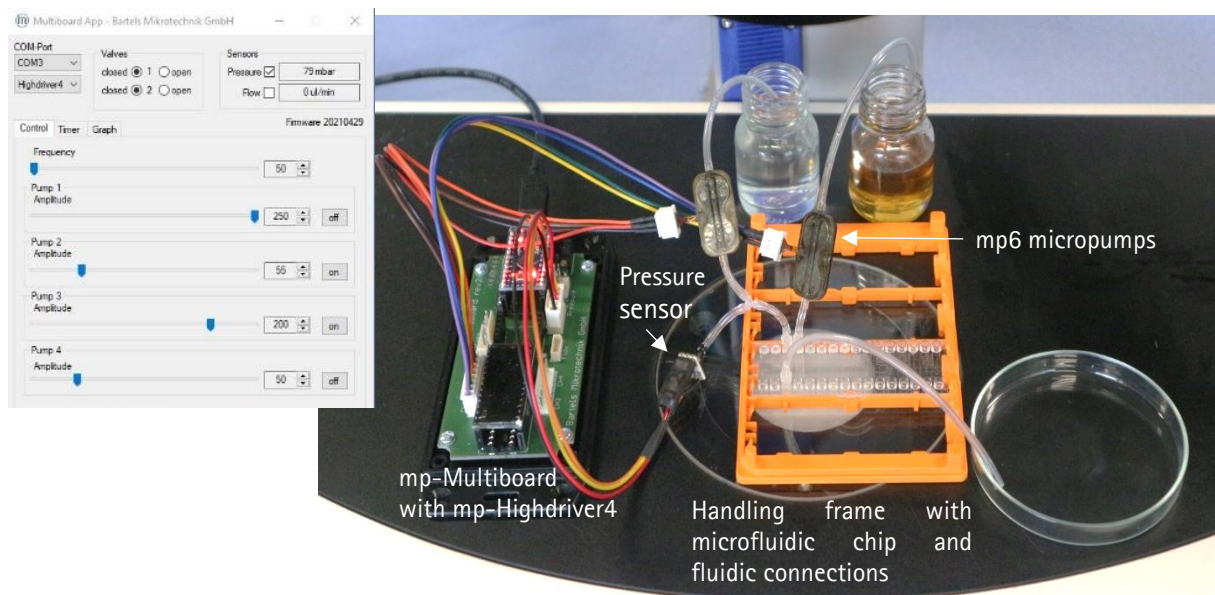
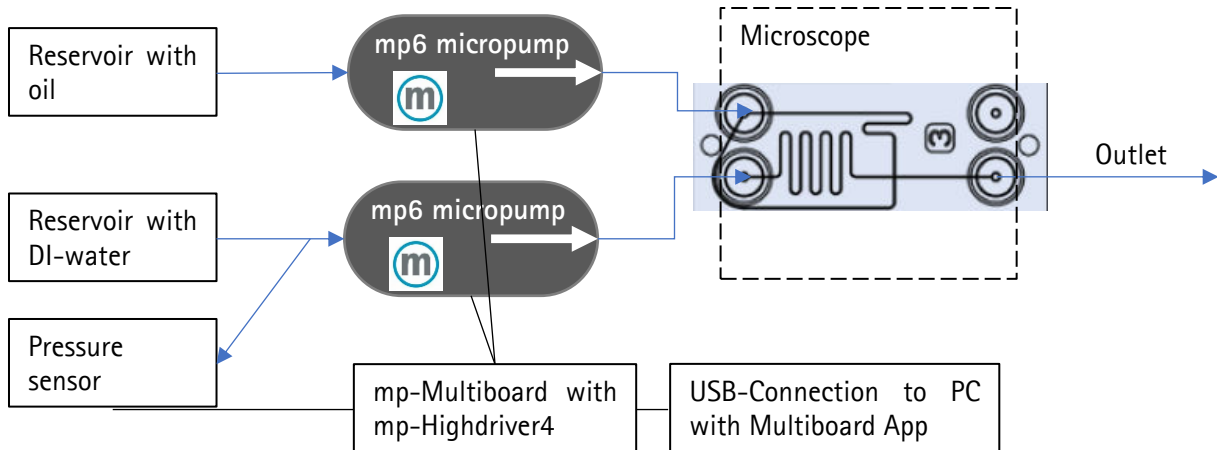

Figure 3: Setup of the microfluidic system used for droplet generation with microfluidic Chip 912. Above: Schematic, Bottom: In real with control via Multiboard APP on PC

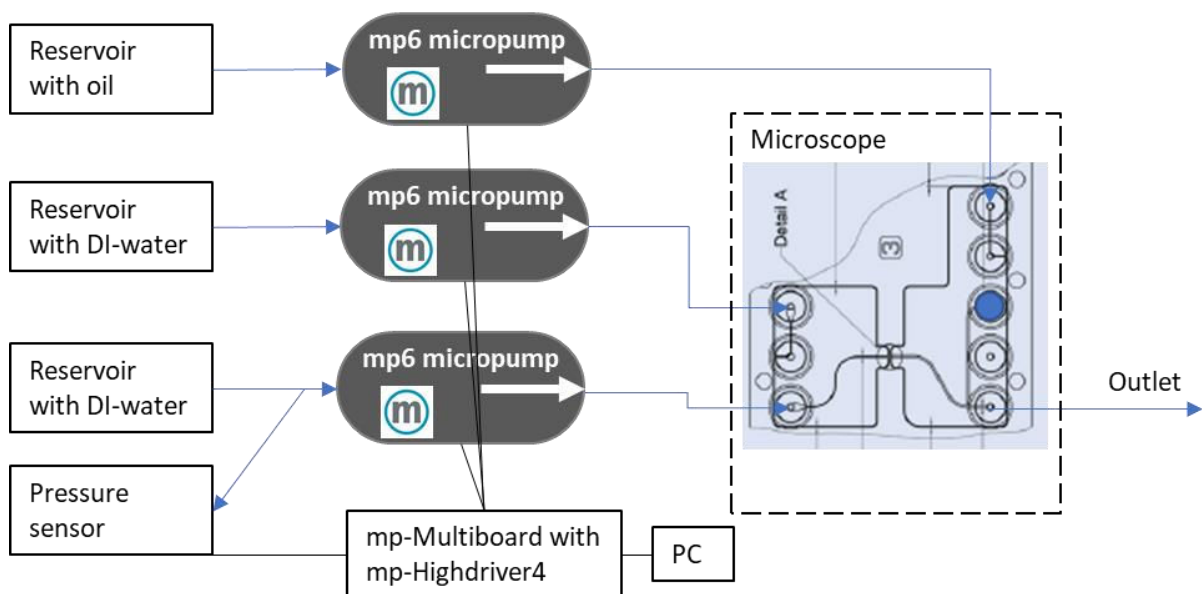

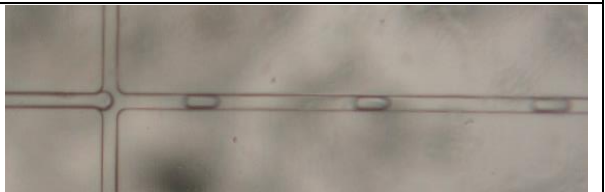

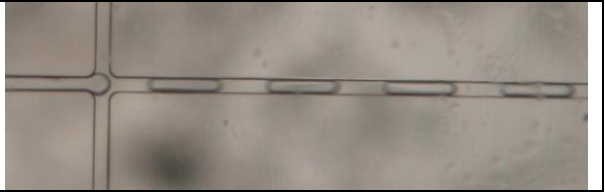
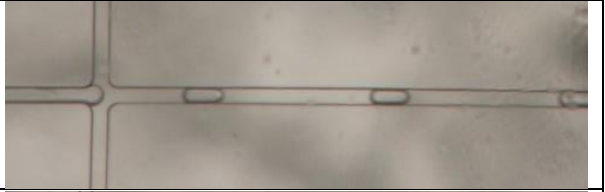
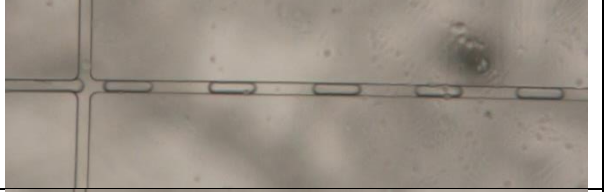
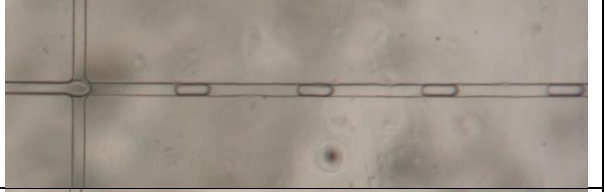



Figure 5: Setup of the microfluidic system used for droplet generation with microfluidic Chip 1032

All values are approximate and no guarantee of specific technical properties.
Changes in the course of technical progress are possible without notice.

Experimental Results

Table 1: water-in-oil droplet generation with microfluidic chip 912 as a function of the flow rate and the pressure

Water		Oil		Droplets		Picture
Q [$\mu\text{l}/\text{min}$]	p [mbar]	Q [$\mu\text{l}/\text{min}$]	p [mbar]	Length [μm]	Rate [Hz]	
6,05	54	7,0	195	123	1	
9,6	70	7,0	195	197	2,5	
13,3	88	7,0	195	270	3,3	
16,7	105	7,0	195	424	4	
6,05	54	4,7	130	221	1,8	
9,6	70	4,7	130	351	2,5	
9,2	51	0,6	80	320	1,8	
12,8	67	0,6	80	600	2	

All values are approximate and no guarantee of specific technical properties.
Changes in the course of technical progress are possible without notice.



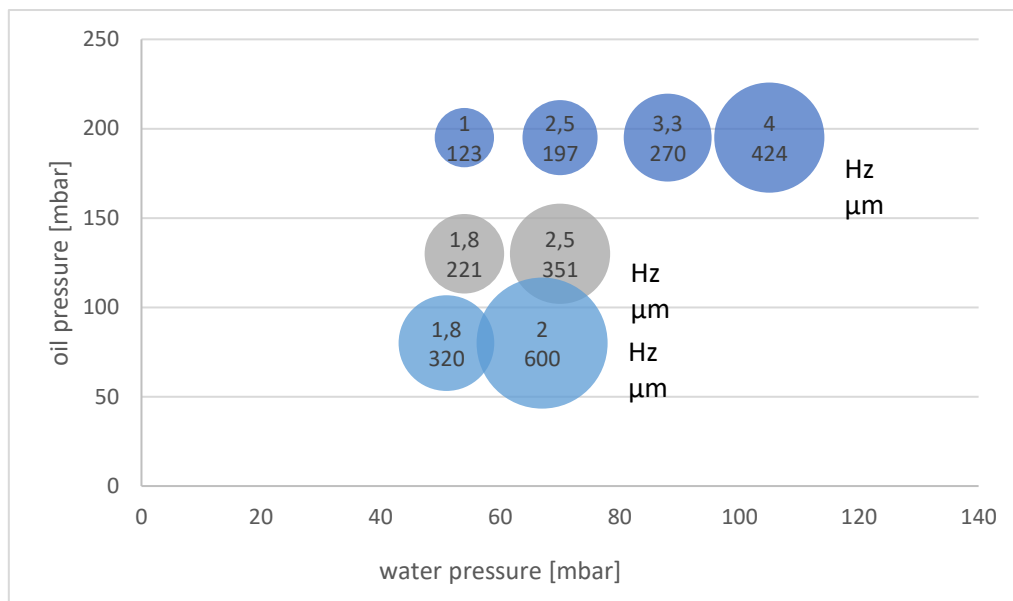
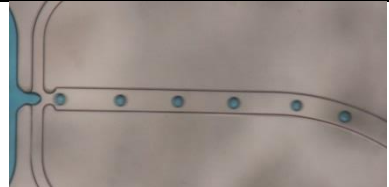
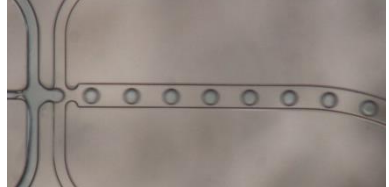



Figure 6: Summary of droplet length and generation rate for water-in-oil droplet generation as a function of the pressure

Next, same measurements are done with the microfluidic chip 1032. Because of the different channel width and flow focusing junction smaller droplets than the channel width can be generated. The droplet size depends on the pressure applied through the mp6. With increasing water pressure and constant oil pressure the droplet size increases as well as the generation rate. Due to non-automated counting, it is not possible to distinguish between counts higher than 4 Hz.

In general it can be shown that it is possible to generate monodisperse droplets in various sizes by using the micropump mp6 and microfluidic chips.

Table 2: water-water/beads-in-oil droplet generation with microfluidic chip 1032 as a function of the flow-rate and the pressure

Water		Water		Oil		Droplets		Picture
Q [μl/min]	p [mbar]	Q [μl/min]	p [mbar]	Q [μl/min]	p [mbar]	diameter [μm]	Rate [Hz]	
3,5	41	3,5	41	7,0	195	97	4	
9,6	70	9,6	70	7,0	195	122,2	>4	
16,7	100	16,7	100	7,0	195	166,6	>4	

All values are approximate and no guarantee of specific technical properties.
Changes in the course of technical progress are possible without notice.

Components and systems used:

- mp6 micropump by Bartels Mikrotechnik
- mp-Multiboard incl. Mp-Highdriver4 by Bartels Mikrotechnik
- Fluidic 912 by microfluidic ChipShop
- Fluidic 1032 by microfluidic ChipShop
- ABP pressure sensor by Honeywell
- SLF3s-0600f by Sensirion

Acknowledgement:

Our Partner, *microfluidic ChipShop* from Jena, Germany, was instrumental in defining our research path, whereby we were able to develop great solution for generating droplets. For that, we are extremely grateful and we are looking forward to our close collaboration. In case you are interested in the above-described microfluidic components or if you are interested in getting in touch with either one of us, *microfluidic ChipShop* or Bartels Mikrotechnik, please feel free to contact us. You can find the contact details below. Also, check out the microfluidic ChipShop website to learn more about their whole portfolio: <https://www.microfluidic-chipshop.com/>





Bartels Mikrotechnik is a globally active manufacturer and development service provider in the field of microfluidics. In the microEngineering division, the company supports industrial customers in the modification, adaptation and new development of high-performance and market-oriented product solutions through the innovative means of microsystems technology. The second division, microComponents, produces and distributes microfluidic products and systems, especially for miniaturized and portable applications. Our key products are micropumps that convey smallest quantities of gases or liquids and are used in a variety of ways in biotechnology, pharmaceuticals, medical technology and numerous other applications.

Bartels Mikrotechnik with passion for microfluidics!

Contact us:

Bartels Mikrotechnik GmbH
Konrad-Adenauer-Allee 11
44263 Dortmund Germany

www.bartels-mikrotechnik.de
info@bartels-mikrotechnik.de
Tel: +49-231-47730-500

Follow Bartels:

